

ZULJANA'S TOUCHSCREEN MONITOR ZL101TMBCAP

TOUCHSCREEN MONITORS - CUSTOM TOUCH SCREEN

Zuljana is among the most relied-on Touchscreen Monitors manufacturers with years of experience offering significant OEMs throughout all markets. Touchscreen monitors solutions are known for their performance in a few of the toughest applications.

Our sensors are customized to your one-of-a-kind application requirements based mainly on projected capacitive (PCAP) touchscreen monitors technology. BaoBao Industrial additionally supplies integration with custom touchscreen monitors LCD/OLED displays, cover lenses, and also peripherals.



Industrial Monitors Features

- ▶ Driver support for all the current operating syst
- ▶ A+ quality LED backlight panels
- ▶ 10-Finger-Multi Touch Capacitive Touch Panel
- ▶ Patented IP65 front with silicon seal
- ▶ The most common video connectors available
- ▶ High resolution LCD Panels
- ▶ Reinforced front glass
- ▶ 1 year guarantee

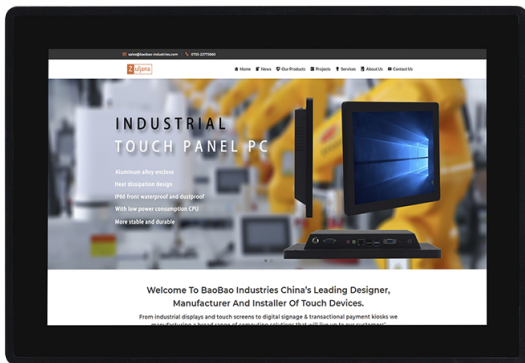

Ordering information

10.1" LCD, 500 nits (Optional), 700:1, 1280x800 pixels, 21.80(H) x 13.66(V), LED Backlight

Rating

IP65 Front / IP40 Back

LCD Panel

Screen Diagonal (Inch/cm)	10.1/25.65
Active Display Area(cm)	21.80(H) x 13.66(V)
Aspect Ratio	16:10
Physical Resolution	1280x800
Maximum showable resolution	1920x1080
Colours Displayed	16.7M
Brightness (cd/m2)	500
Contrast	700:1
Typical Reaction Time Tr/ Tf (ms)	10/15
Visual Angle Horizontal / vertical (°)	150/145
Backlight/Backlight Lifetime (hours)	LED/20,000

Touch Panel

Touch Technology	Projected Capacitive 10-point Multitouch
Touch Panel Drivers	Windows; Linux; Mac; Android
Touch Life (Contacts)	Unlimited
Surface Hardness	7H
Surface Treatment	Anti-glare (optional)
Glass Strengthening	Tempered glass

Product Name

10.1" Capacitive Touch Monitor

Model Number

ZL101TMBCAP

Operation/Mechanical

Operating Temperature (°C)	-10~+60
Humidity Range (RH)	10%-90%
Net Weight (Kg)	1.10
Gross Weight (Kg)	2.30 (Incl. cartilage)
Housing Material	Aluminum front/back case
Housing (mm) L x W x H	26.00 x 17.80 x 3.80
Mounting	VESA 75

External Connectors

Video	1x HDMI 1.3 (Incl. HDCP)
	1x DVI-D
	1x VGA
Audio	1x PC-Audio
	1x USB
Touch Connector	1x USB
	1x 12V DC-IN

Power

Power Indicator	Green LED
Power Supply	100-240V ACDC Active Switching;
	12V DC-Out
Working Power (V)	12
Working Power (w)	8
Stand-By Consumption	<1

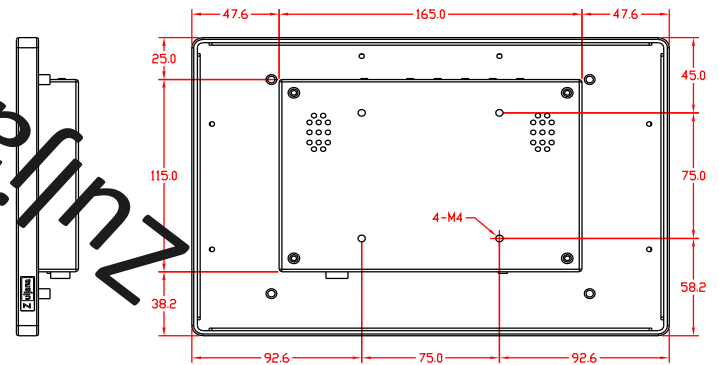
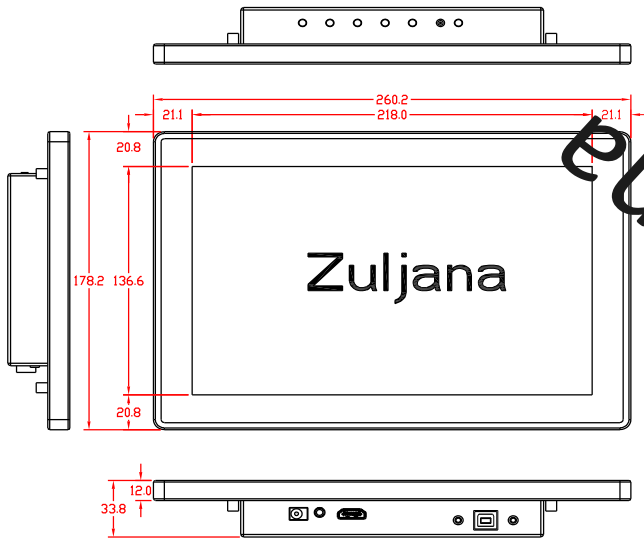

Learn more about Zuljana at baobao-industries.com

- +86 755 23775660
- +86 755 23779143
- sales@baobao-industries.com
- <https://www.baobao-industries.com>

